

MWA Antenna Instructions

A. Ground Screen

Ground screen materials are not included with the MWA antenna and must be acquired locally. Install the ground screen before the antenna. The recommended Tile ground screen for sixteen antennas consists of three 2 x 5 m (6.6 x 16.4 ft) mesh panels overlapped by 0.5 m (1.6 ft) to form a 5 x 5 m (16.4 x 16.4 ft) square. The individual panels are made of 3.15 mm (0.125 in, 10 AWG) diameter galvanized steel wire, welded to form a grid or mesh of 5 x 5 cm (2 x 2 in) squares. Fasten the mesh panels together with galvanized tie wires made from extra mesh material or fence crimp sleeves. It is recommended that an installation consisting of one antenna use a 3 x 3 m (10 x 10 ft) ground screen of 2 in or smaller square, heavy-duty, galvanized steel mesh. Orient the screen grid pattern with respect to true north-south, east-west. Anchor the ground screen with 9 in ABS plastic or galvanized steel tent pegs.

B. MWA Antenna Assembly (reference figures 1 to 4)

1. Remove items from packaging and inspect for damage and missing parts.
2. Adjust plastic foot to maximum possible length. Note: The foot height adjusting screws often come loose in transport, so always check them.
3. Move LNA board slightly out of the way by raising up the coaxial cables.
4. Insert each bat-wing antenna element key into a central hub slot with the foot facing down (*down* is defined by the plastic tube containing the coaxial cables in the central hub).
5. Check tightening torque of the SMA cable connectors on the LNA board (8-10 in-lb or 90-113 N-cm).
6. Seat the LNA Board. Check and, if necessary, update the external "North" marking. Note: The external marking (Sharpie) that indicates north (actually, north-northwest) is sometimes 180-degrees out, so always check orientation.
7. Fit 4 x M4 screws into the LNA terminals, being careful to not cross-thread or over-tighten and strip the threads. Ensure proper seating by bending lugs if necessary before tightening screws.
8. Overcoat the completed LNA/bat-wing assembly with a quick spray of Plasti Dip: <https://plastidip.com/>. Apply 2nd coat of Plasti Dip after the first coat sets (follow directions on can). Note: The use of Plasti Dip is required at the MRO due to the acid-rich soil and is not required for antennas installed in more benign environments.
9. Screw on the LNA lid.
10. The antenna is now ready to install on the Tile ground screen.

C. MWA Antenna Installation on Ground Screen

1. Decide the position of each antenna on the Tile (the MRO uses a 1.1 m center-to-center spacing). A single antenna is centered on the ground screen.
2. Orient all antennas in a Tile or single antenna so the "north" mark is pointed the same direction.
3. Align the central hub tube over a mesh-wire crossing. The legs should be aligned with the middle of a mesh cell.
4. Push down gently on the legs to snap the feet into place.
5. Level the antenna by adjusting the feet. The feet normally are set to 10 cm height.
6. Route the coaxial cables away from the antenna at approximately 45° with respect to the antenna elements.

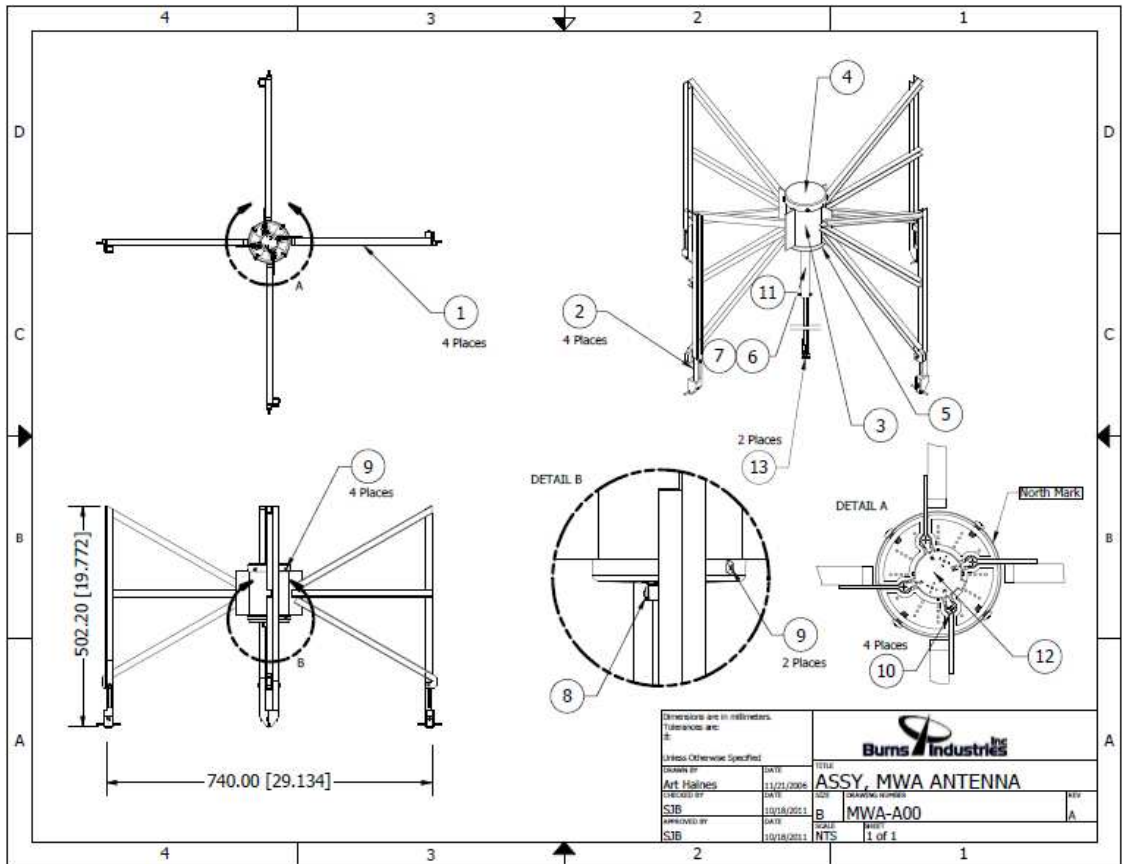

Figure 1 ~ MWA antenna assembly:
 (1) Antenna element;
 (2) Foot assembly;
 (3) Central hub;
 (4) Central hub cap;
 (5) Central hub base;
 (6), (7) Coaxial cable tube assembly.

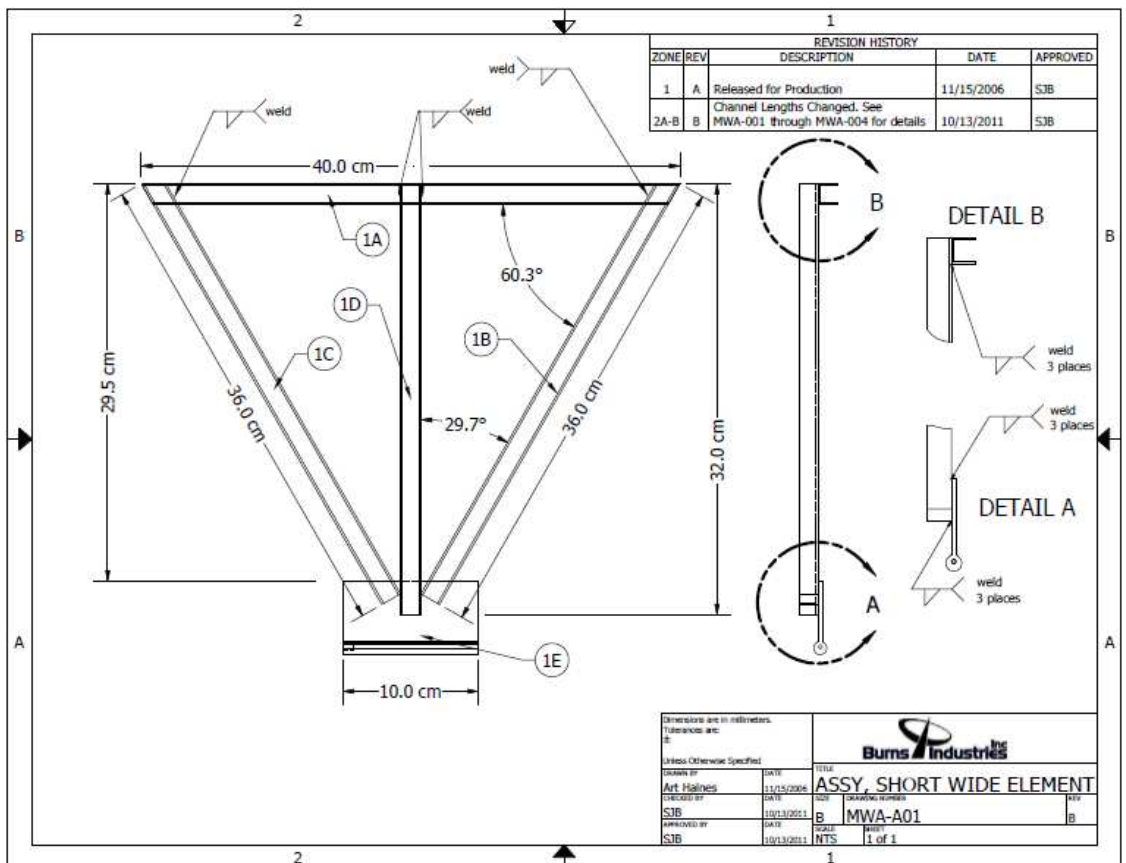

Figure 2 ~ MWA antenna element assembly

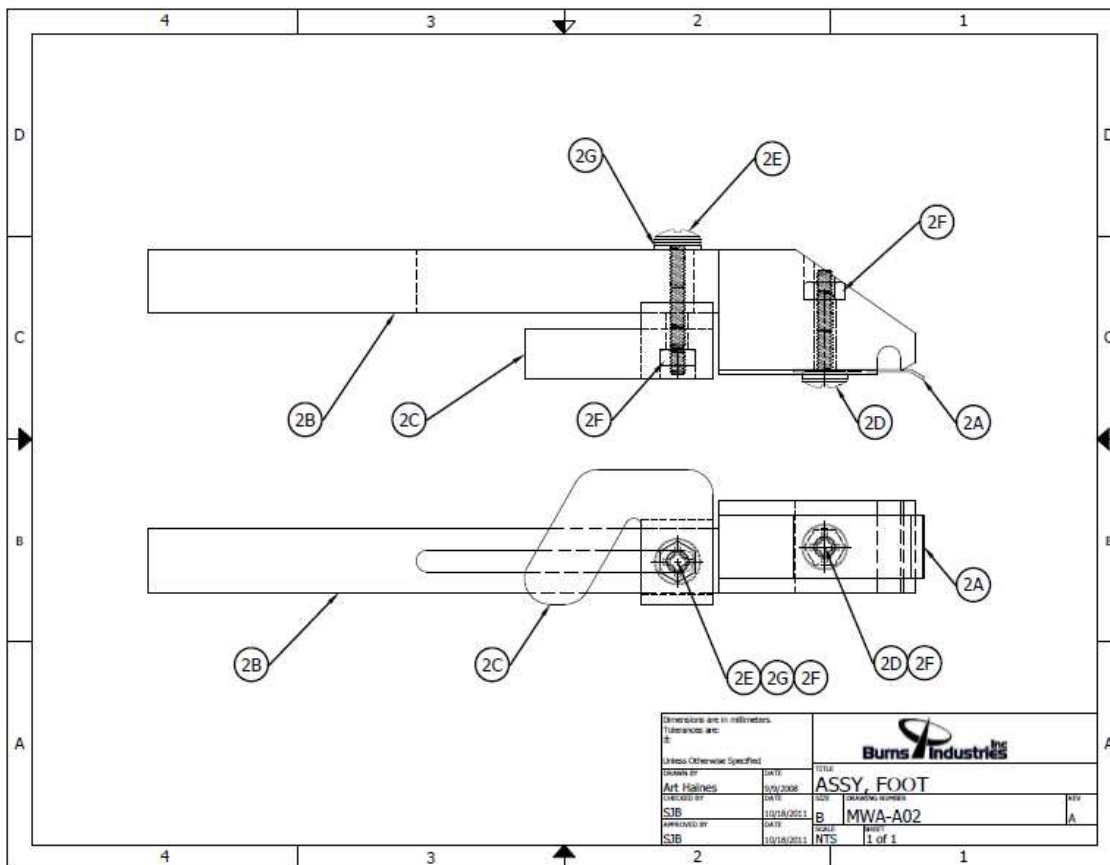

Figure 3 ~
MWA antenna
foot assembly

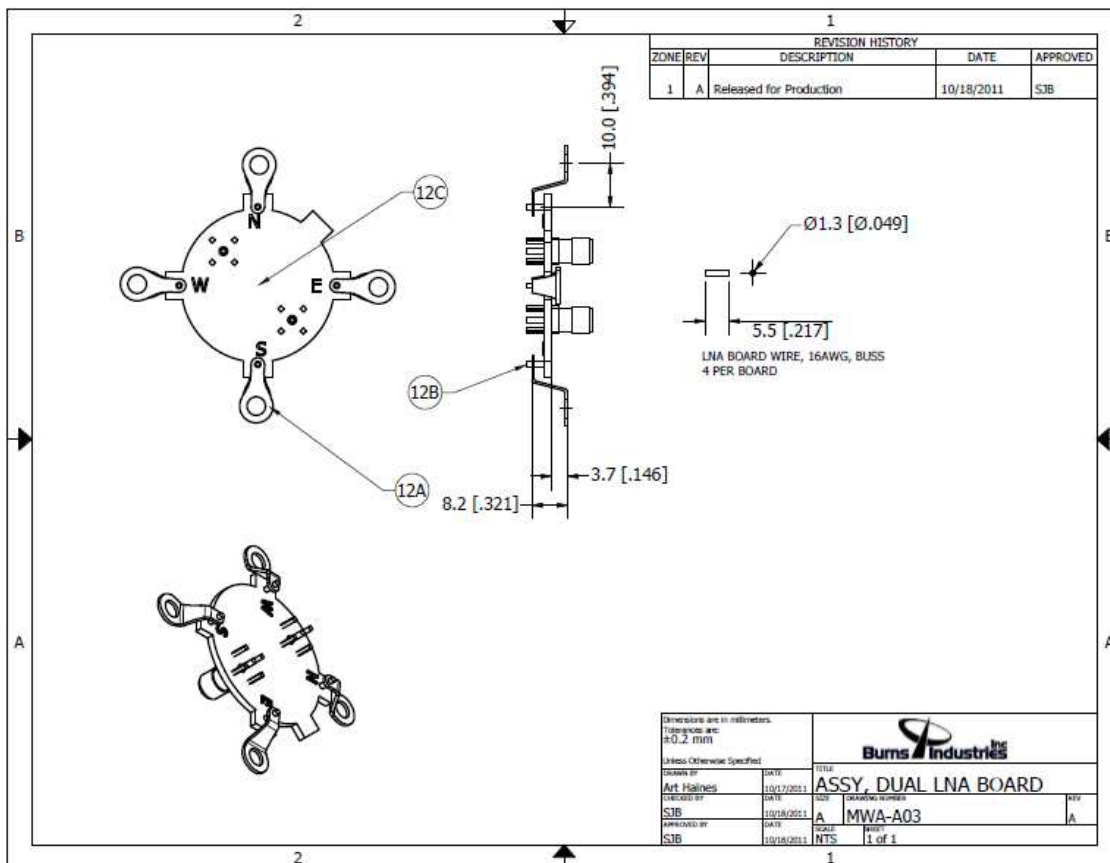

Figure 4 ~
MWA dual low
noise amplifier
assembly

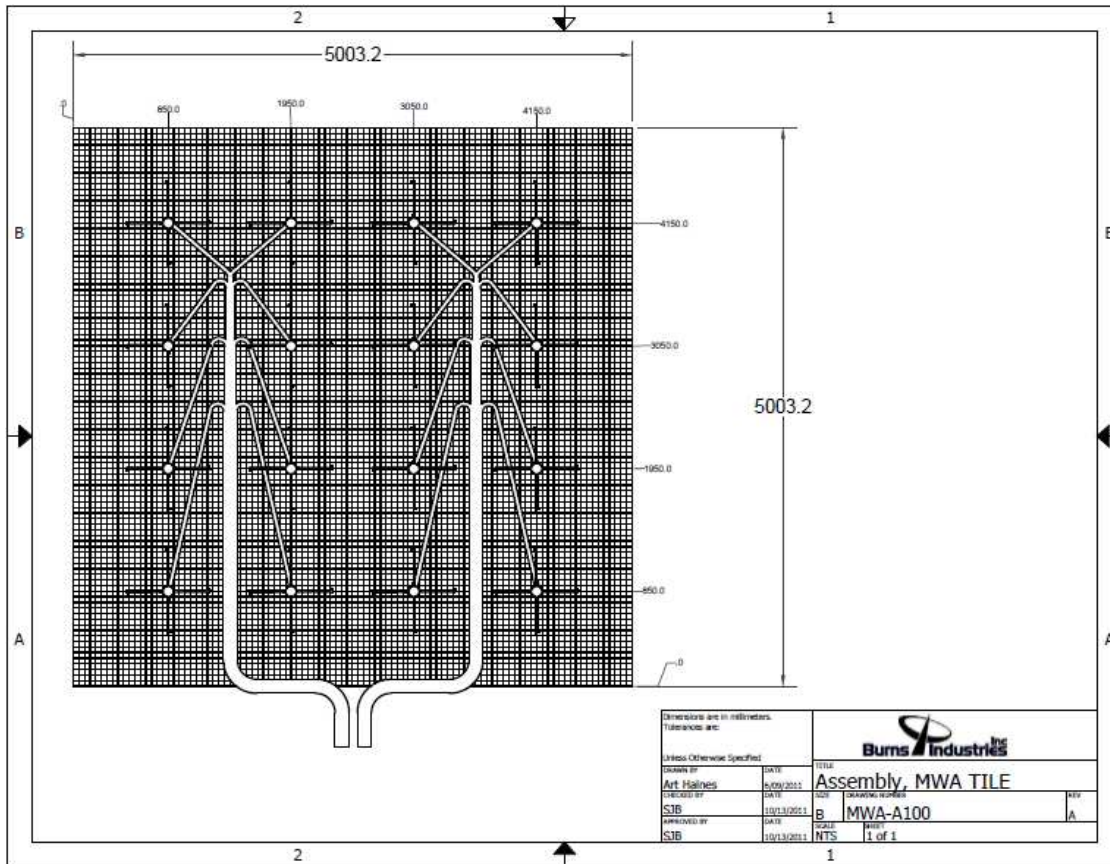

Figure 5 ~ MWA antenna layout for a full Tile installation. In an installation consisting of one antenna, the antenna will be centered on the 3 x 3 m ground screen.

All drawings © Burns Industries and used with permission.

Document information

Author: Whitham D. Reeve

Copyright: © 2017 W. Reeve

Revision: 0.0 (Original draft started, permission pending to use illustrations, 19 May 2017)

0.1 (Obtained permissions, completed initial draft, 23 May 2017)

0.2 (Minor clarifications, 25 May 2017)

Word count: 2546

File size: 266240