

8 7 6 5 4 3 2 1

H

H

G

G

F

F

E

E

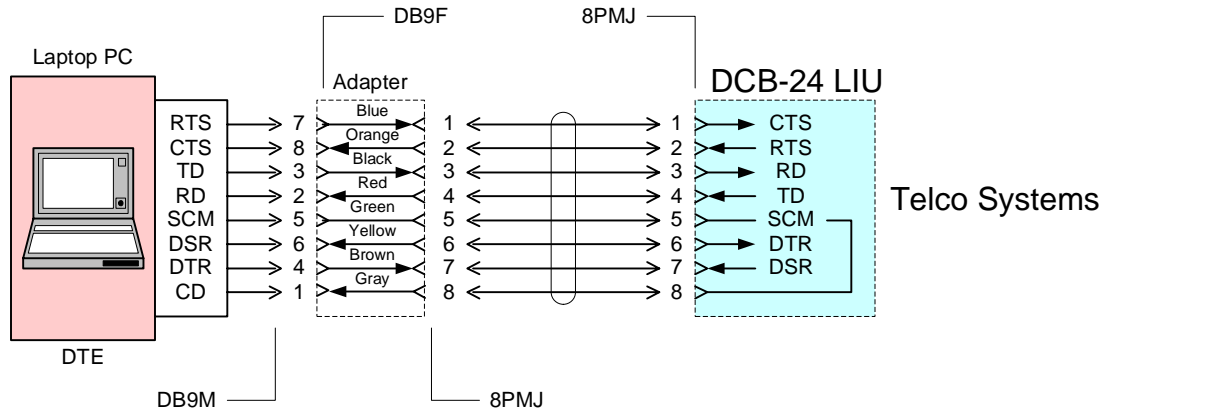

D

D

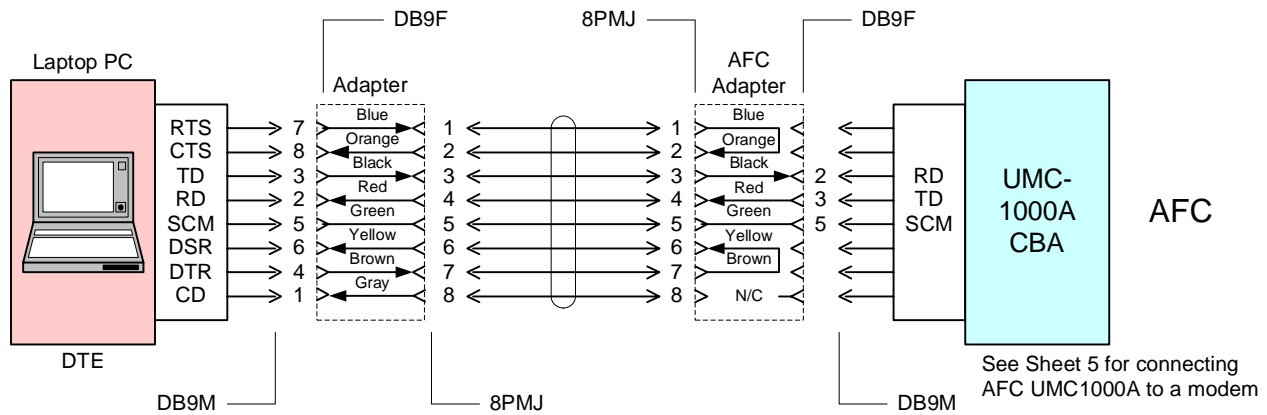

C

C

B

B

Adapter p/n (Milestek):
 DB9M 10-01042
 DB9F 10-01043
 DB25M 10-01046
 DB25F 10-01047

Revisions		© 1999 Reeve Engineers	
A	Orig. 1/20/97	PC and Equipment Serial Port Adapter Wiring	
B	Upd. 5/23/97	<i>Reeve Engineers, Anchorage, AK</i>	
C	Cor. 11/27/98	File: Serial Port Adapters.vsd	DWG. PC-ADAPT
		Scale: None	Sheet 1 of

A

A

8 7 6 5 4 3 2 1

8 7 6 5 4 3 2 1

H

H

G

G

F

F

E

E

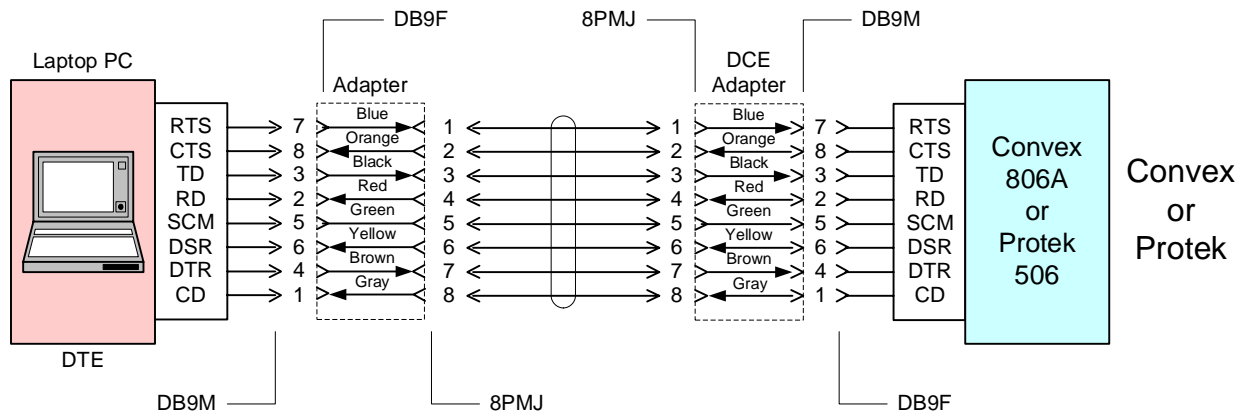

D

D

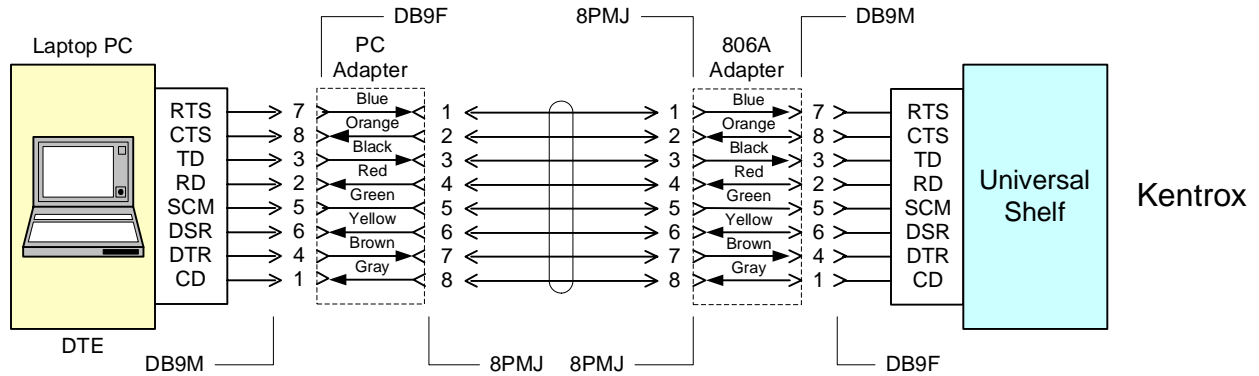

C

C

B

B

A

A

Adapter p/n (Milestek):
 DB9M 10-01042
 DB9F 10-01043
 DB25M 10-01046
 DB25F 10-01047

Revisions		© 1999 Reeve Engineers	
A	Orig. 5/23/97	PC and Equipment Serial Port Adapter Wiring	
B	Cor. 11/27/98		
C	Upd. 12/24/98		
		<i>Reeve Engineers, Anchorage, AK</i>	
		File: Serial Port Adapters.vsd	DWG. PC-ADAPT
		Scale: None	Sheet 2 of

8 7 6 5 4 3 2 1

8 7 6 5 4 3 2 1

H

H

G

G

F

F

E

E

D

D

C

C

B

B

A

A

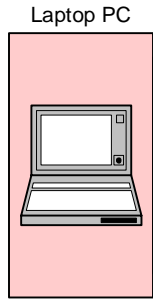

RTS
CTS
TD
RD
SCM
DSR
DTR
CD

7
8
3
2
5
6
4
1

DTE

DB9M

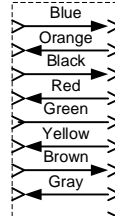
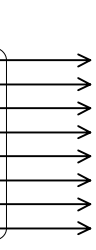
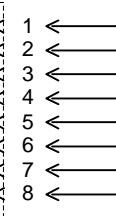
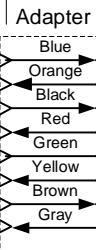

RTS
CTS
TD
RD
SCM
DSR
DTR
CD
RI

Modem

DB25F

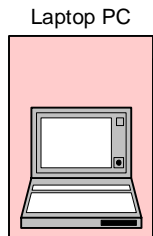

RTS
CTS
TD
RD
SCM
DSR
DTR
CD

7
8
3
2
5
6
4
1

DTE

DB9M

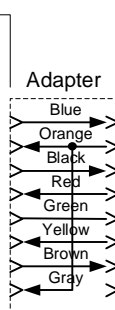
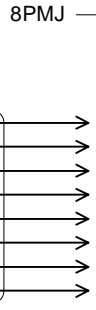
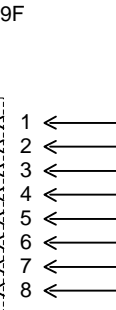

CTS
RTS
RD
TD
SCM
DTR
DSR
CD

TDS210

Tektronix

DB9M

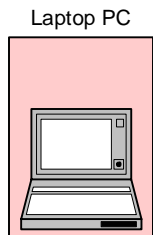

RTS
CTS
TD
RD
SCM
DSR
DTR
CD

7
8
3
2
5
6
4
1

DTE

DB9M

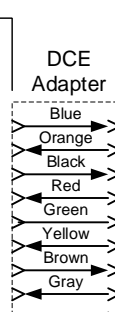
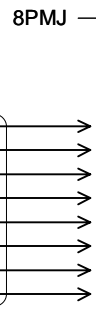
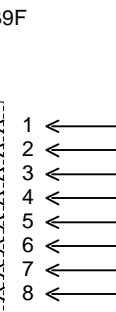
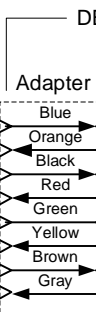

RTS
CTS
TD
RD
SCM
DSR
DTR
CD

224

TTC

DB25F

Adapter p/n (Milestek):
DB9M 10-01042
DB9F 10-01043
DB25M 10-01046
DB25F 10-01047

Revisions		© 1999 Reeve Engineers	
A	Orig. 5/24/97	PC and Equipment Serial Port Adapter Wiring	
B	Add. 3/27/98		
C	Add. 11/27/98		
		Reeve Engineers, Anchorage, AK	
		File: Serial Port Adapters.vsd	DWG. PC-ADAPT
		Scale: None	Sheet 3 of

8 7 6 5 4 3 2 1

8 7 6 5 4 3 2 1

H H

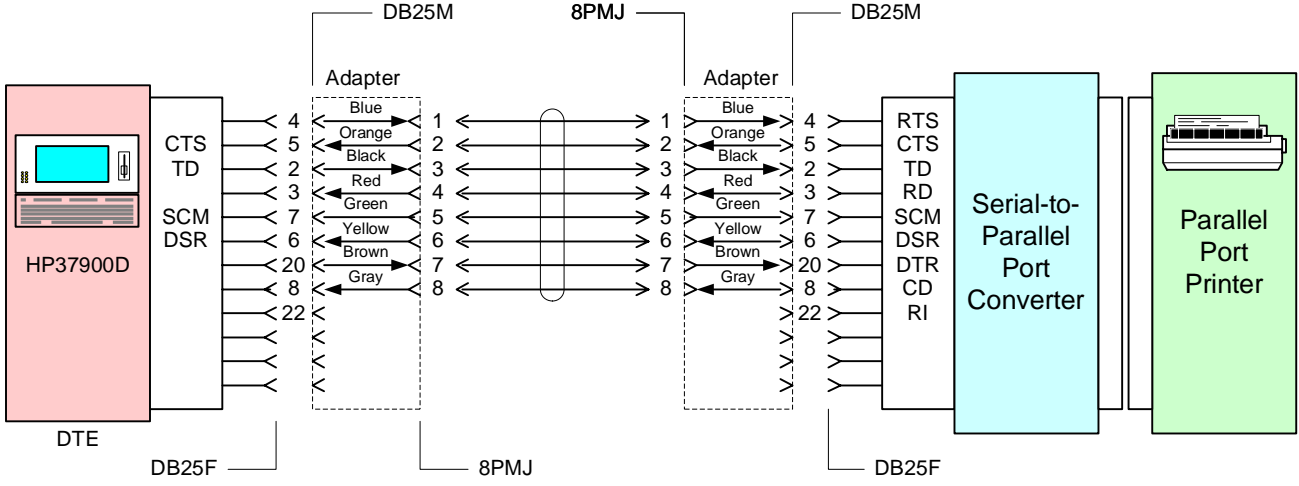

G G

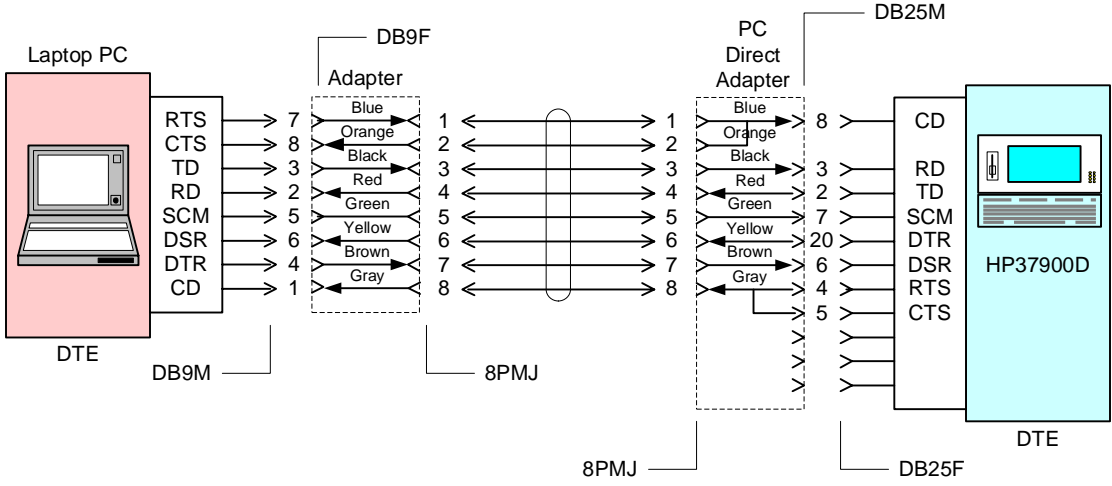

F F

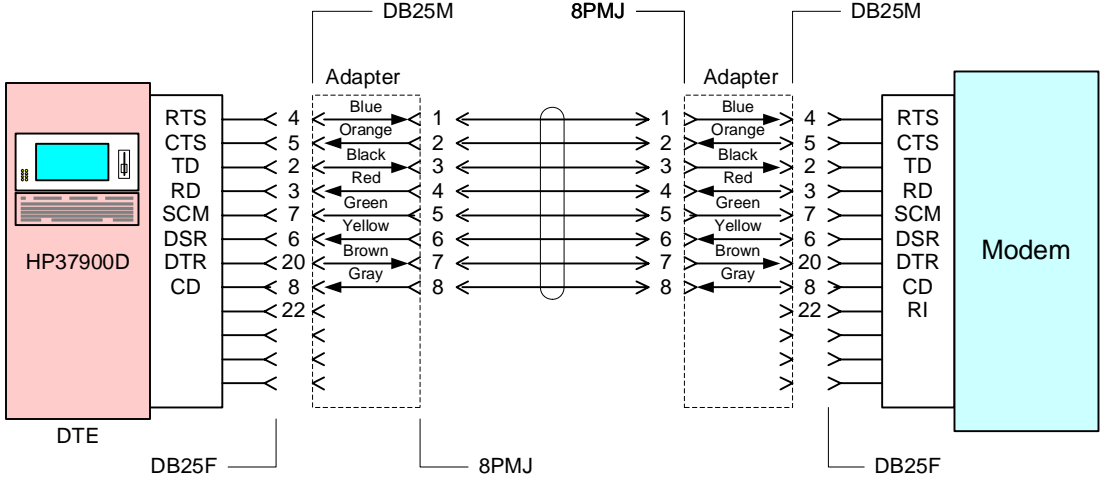

E E

D D

C C

B B

Adapter p/n (Milestek):
 DB9M 10-01042
 DB9F 10-01043
 DB25M 10-01046
 DB25F 10-01047

Revisions		© 1999 Reeve Engineers	
A	Orig. 12/17/98	PC and Equipment Serial Port Adapter Wiring	
B	Add 1/7/99	Reeve Engineers, Anchorage, AK	
C	Add 1/8/99	File: Serial Port Adapters.vsd	DWG. PC-ADAPT
		Scale: None	Sheet 4 of

A A

8 7 6 5 4 3 2 1

8 7 6 5 4 3 2 1

H

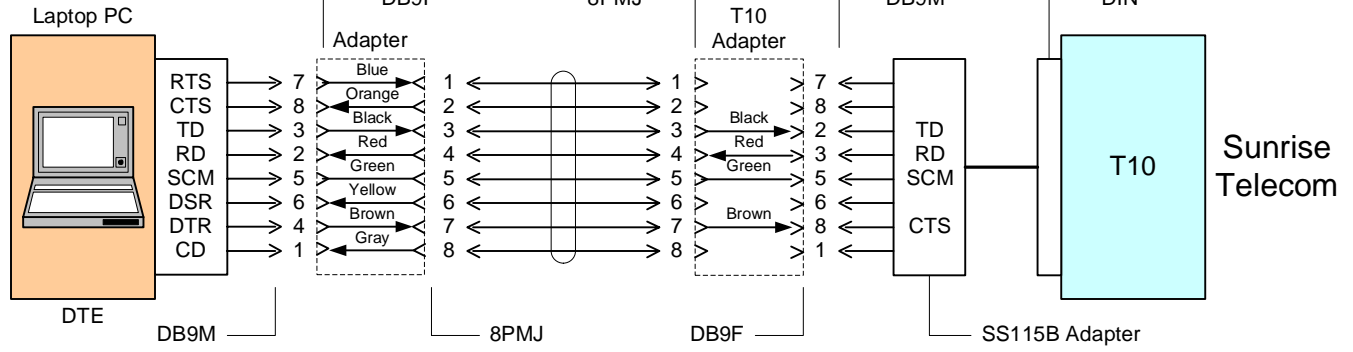

H

G

G

F

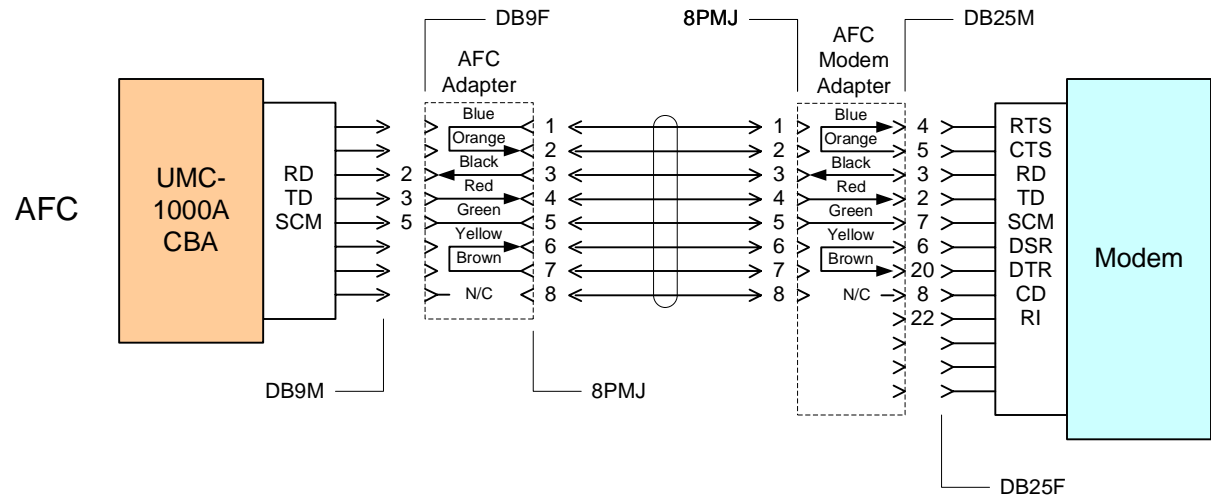

F

E

E

D

D

C

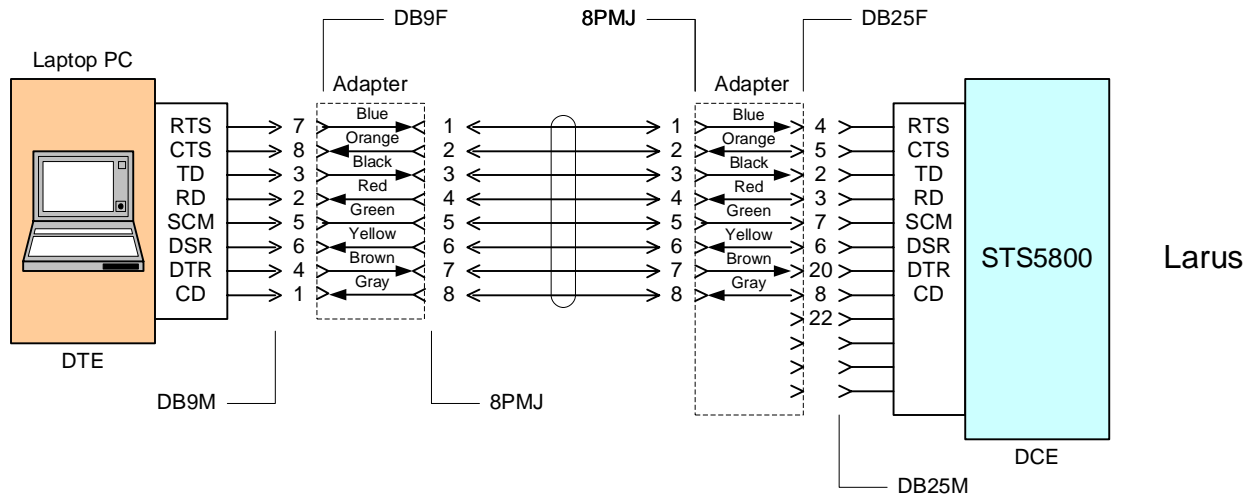

C

B

B

A

Adapter p/n (Milestek):
 DB9M 10-01042
 DB9F 10-01043
 DB25M 10-01046
 DB25F 10-01047

Revisions		© 1999 Reeve Engineers	
A	Orig. 1/8/99	PC and Equipment Serial Port Adapter Wiring	
B	Add 2/22/99	<i>Reeve Engineers, Anchorage, AK</i>	
C	Add 7/7/99		
		File: Serial Port Adapters.vsd	DWG. PC-ADAPT
		Scale: None	Sheet 5 of

A

8 7 6 5 4 3 2 1

8 7 6 5 4 3 2 1

H

H

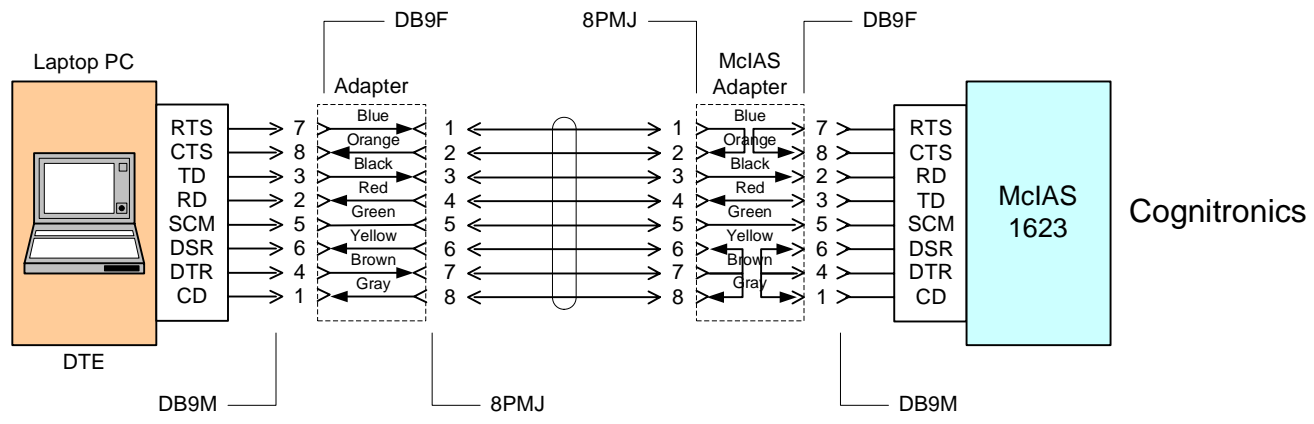

G

G

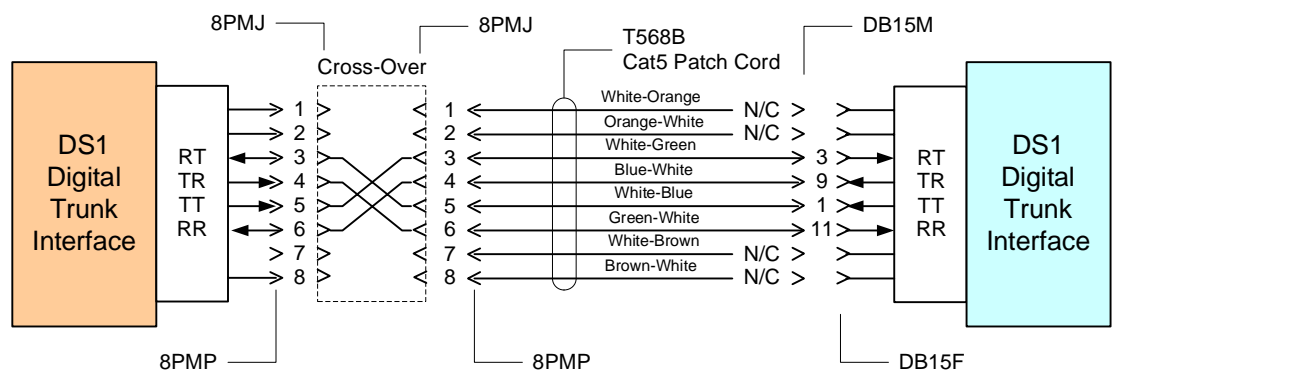

F

F

E

E

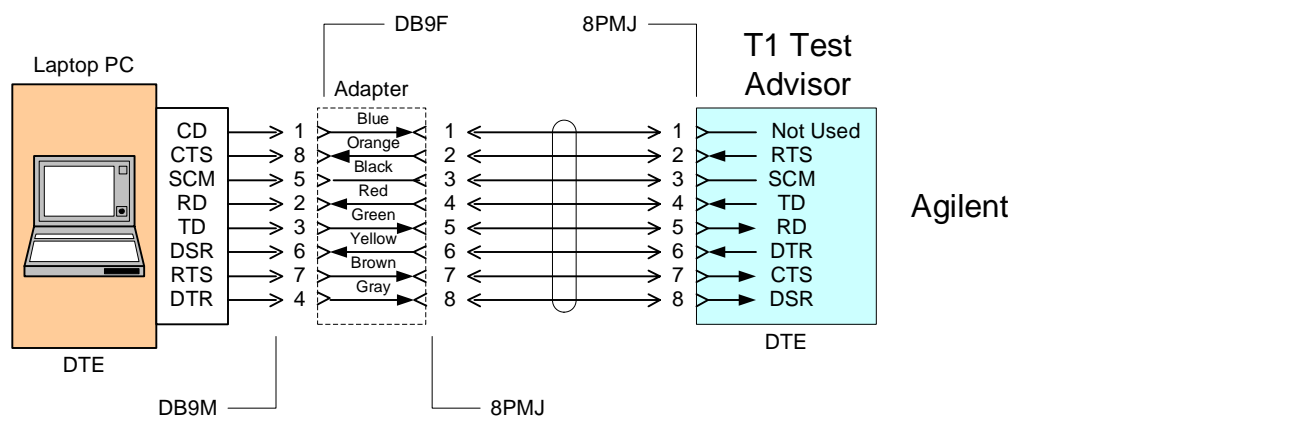

D

D

C

C

B

B

Adapter p/n (Milestek):
 DB9M 10-01042
 DB9F 10-01043
 DB25M 10-01046
 DB25F 10-01047

Revisions		© 1999 Reeve Engineers	
A	Orig. 4/11/99	PC and Equipment Serial Port Adapter Wiring	
B	Add 11/5/99	<i>Reeve Engineers, Anchorage, AK</i>	
		File: Serial Port Adapters.vsd	DWG. PC-ADAPT
		Scale: None	Sheet 6 of

A

A

8 7 6 5 4 3 2 1

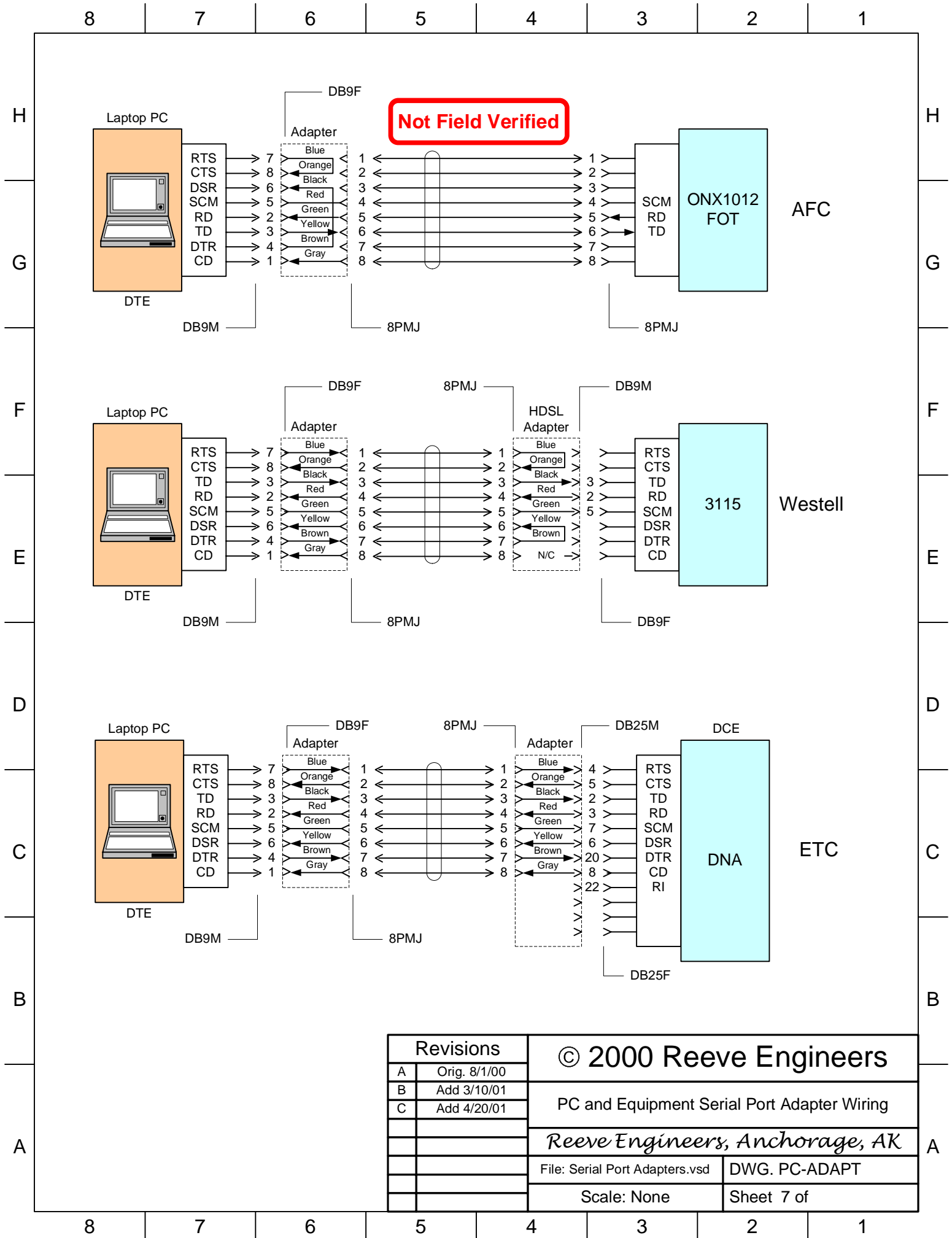

Revisions		© 2000 Reeve Engineers	
A	Orig. 8/1/00	PC and Equipment Serial Port Adapter Wiring	
B	Add 3/10/01	<i>Reeve Engineers, Anchorage, AK</i>	
C	Add 4/20/01	File: Serial Port Adapters.vsd	DWG. PC-ADAPT
		Scale: None	Sheet 7 of

8 7 6 5 4 3 2 1

H

H

G

G

F

F

E

E

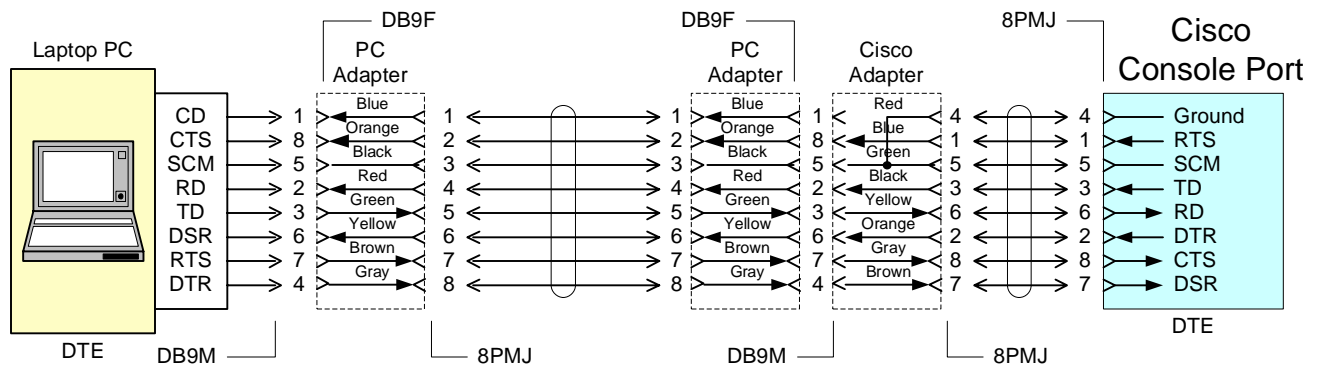

D

D

C

C

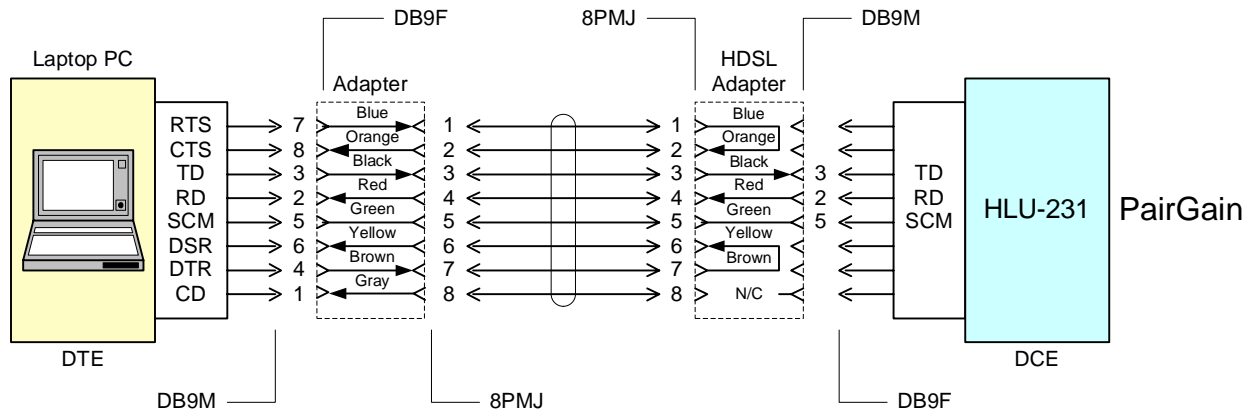

B

B

A

A

Revisions		© 2000 Reeve Engineers	
A	Orig. 4/23/01	PC and Equipment Serial Port Adapter Wiring	
		<i>Reeve Engineers, Anchorage, AK</i>	
		File: Serial Port Adapters.vsd	DWG. PC-ADAPT
		Scale: None	Sheet 8 of

8 7 6 5 4 3 2 1

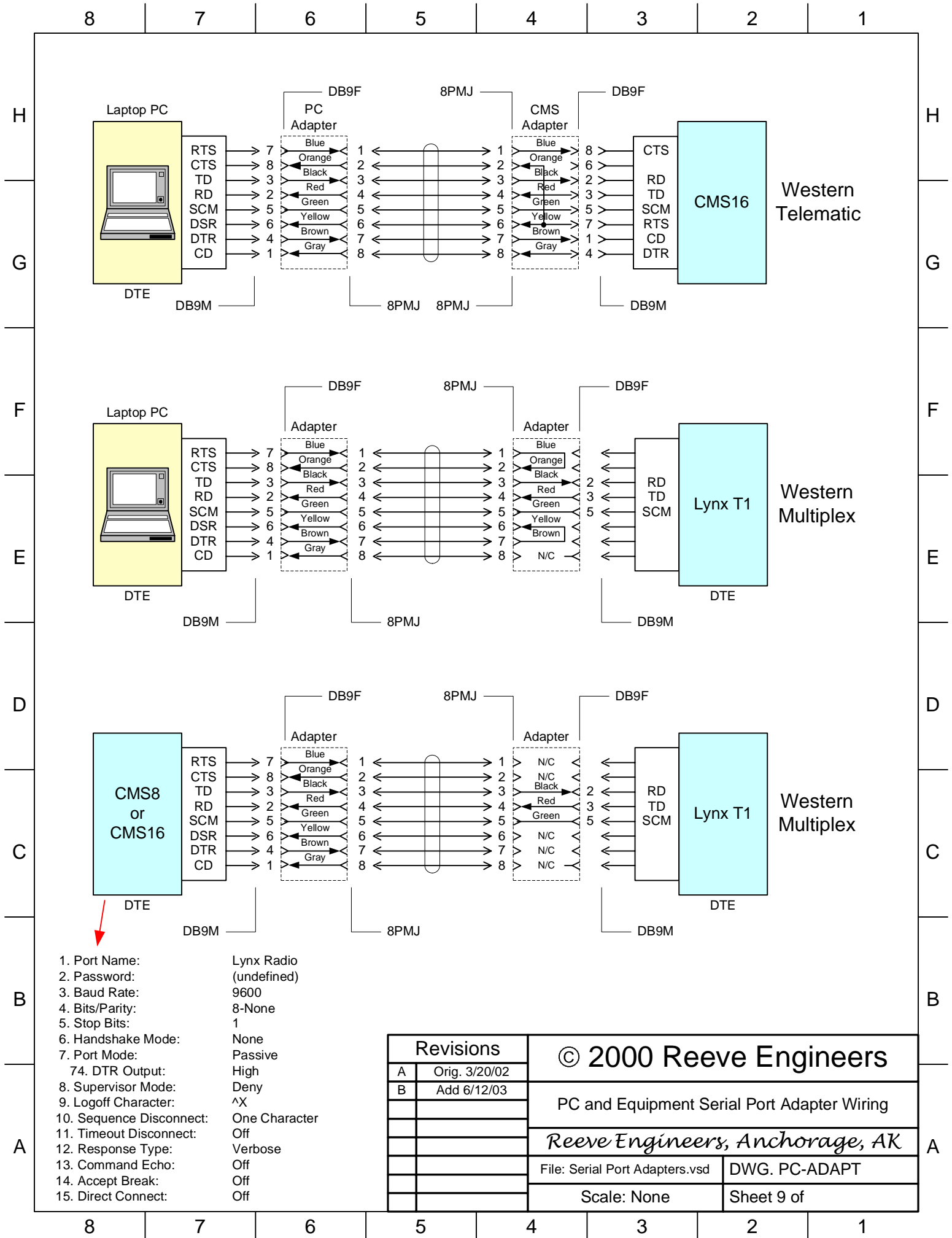

- 1. Port Name: Lynx Radio
- 2. Password: (undefined)
- 3. Baud Rate: 9600
- 4. Bits/Parity: 8-None
- 5. Stop Bits: 1
- 6. Handshake Mode: None
- 7. Port Mode: Passive
- 74. DTR Output: High
- 8. Supervisor Mode: Deny
- 9. Logoff Character: ^X
- 10. Sequence Disconnect: One Character
- 11. Timeout Disconnect: Off
- 12. Response Type: Verbose
- 13. Command Echo: Off
- 14. Accept Break: Off
- 15. Direct Connect: Off

Revisions		© 2000 Reeve Engineers	
A	Orig. 3/20/02	PC and Equipment Serial Port Adapter Wiring	
B	Add 6/12/03		
		Reeve Engineers, Anchorage, AK	
		File: Serial Port Adapters.vsd	DWG. PC-ADAPT
		Scale: None	Sheet 9 of

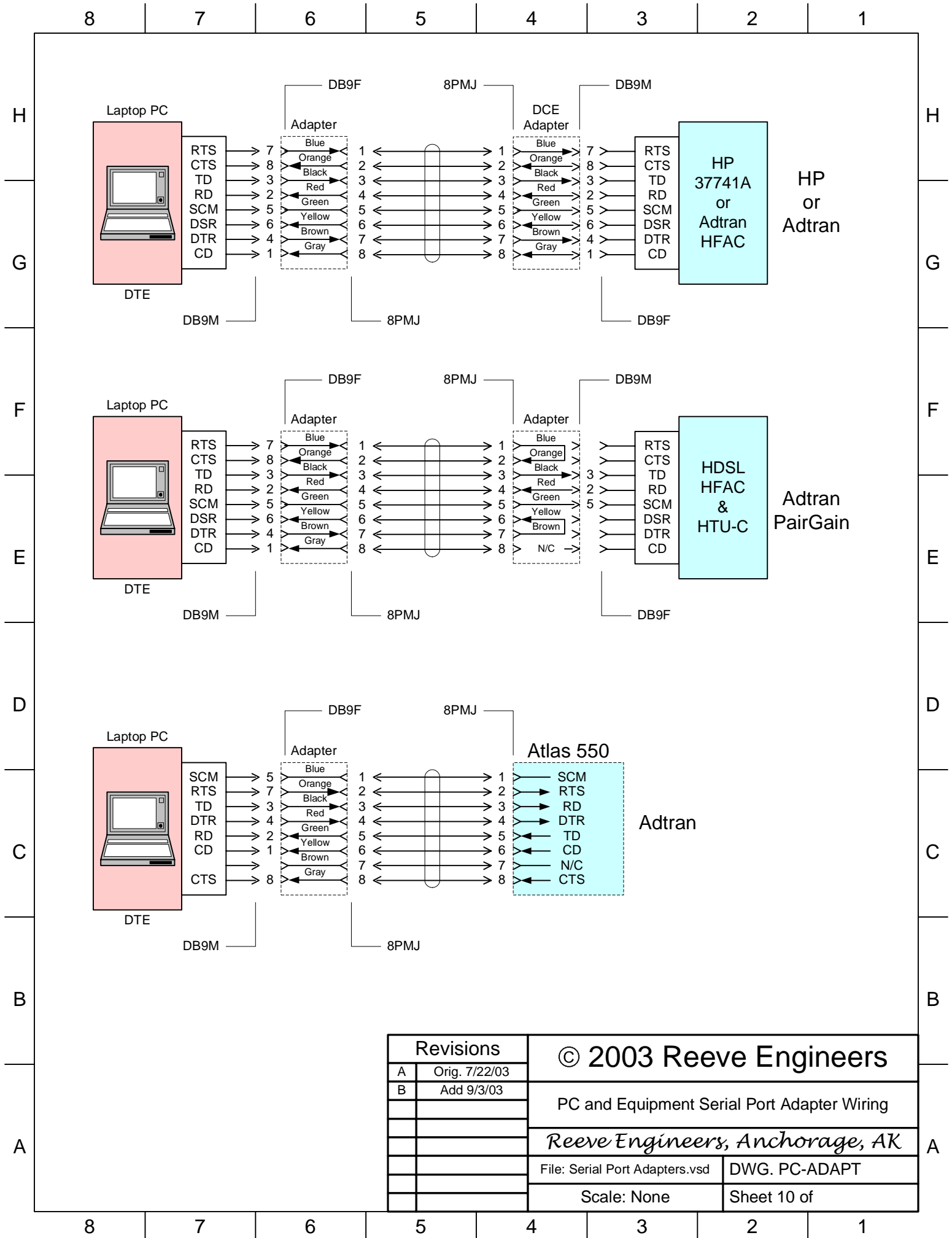

Revisions		© 2003 Reeve Engineers	
A	Orig. 7/22/03	PC and Equipment Serial Port Adapter Wiring	
B	Add 9/3/03	<i>Reeve Engineers, Anchorage, AK</i>	
		File: Serial Port Adapters.vsd	DWG. PC-ADAPT
		Scale: None	Sheet 10 of

8 7 6 5 4 3 2 1

H

H

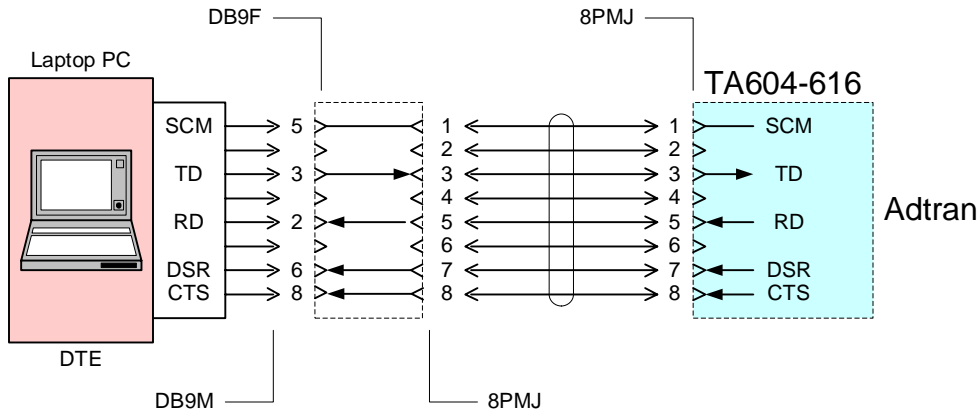

G

G

F

F

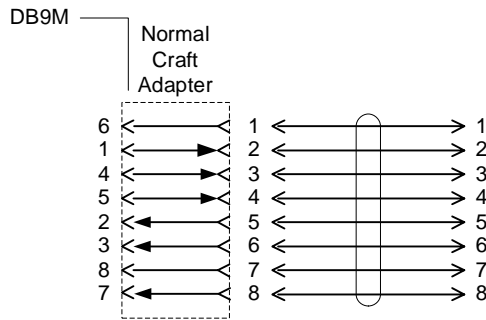

E

E

D

D

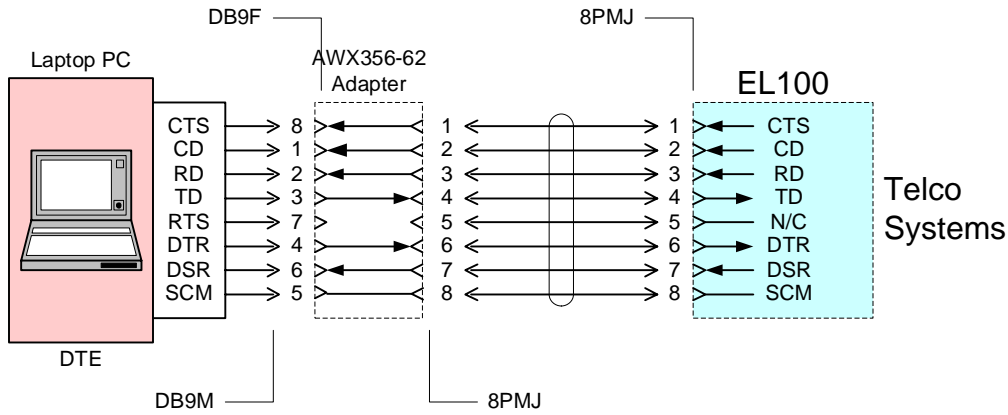

C

C

B

B

A

A

Revisions		© 2003 Reeve Engineers	
A	Orig. 9/06/03	PC and Equipment Serial Port Adapter Wiring	
		<i>Reeve Engineers, Anchorage, AK</i>	
		File: Serial Port Adapters.vsd	DWG. PC-ADAPT
		Scale: None	Sheet 11 of

8 7 6 5 4 3 2 1

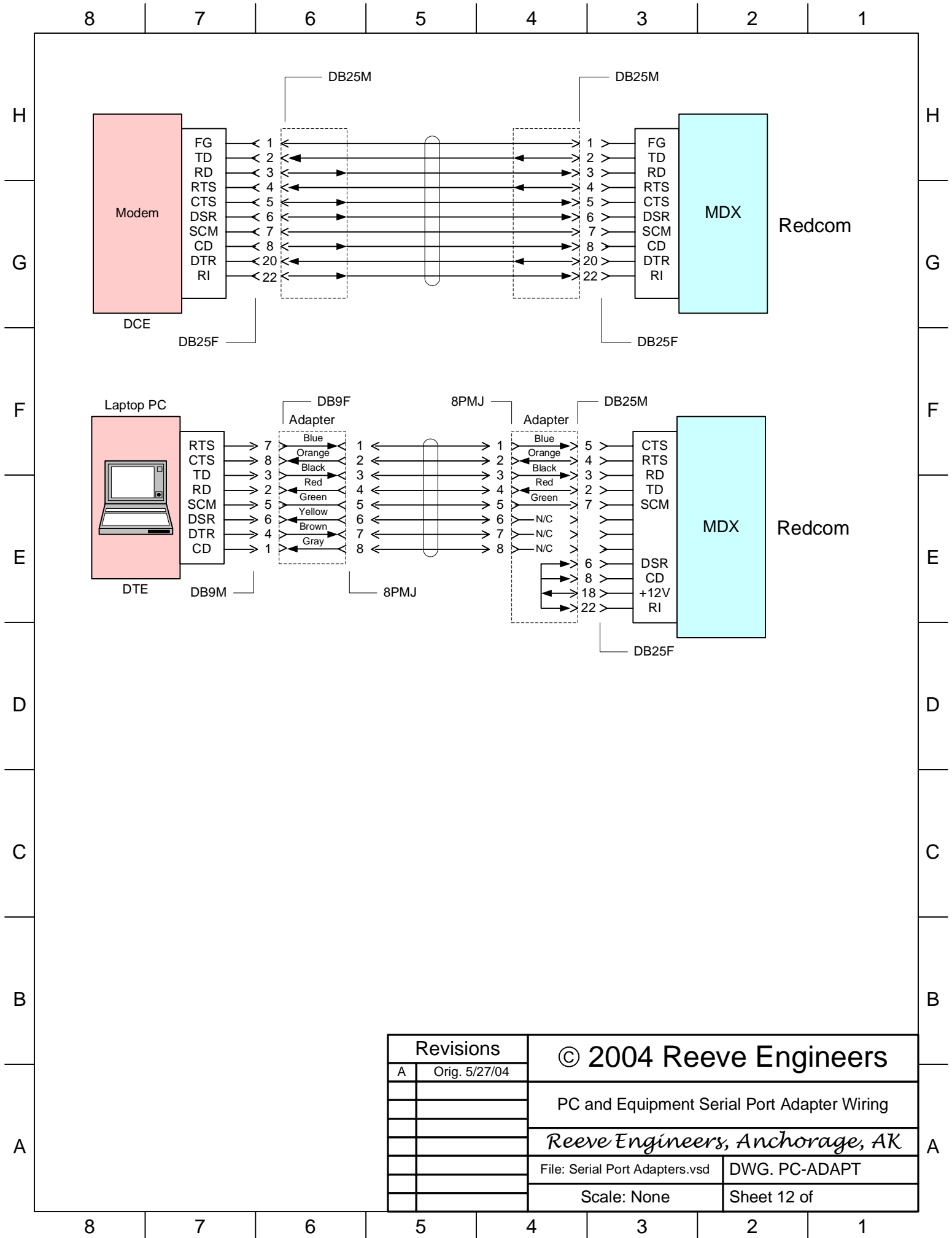

Revisions		© 2004 Reeve Engineers	
A	Orig. 5/27/04	PC and Equipment Serial Port Adapter Wiring	
		<i>Reeve Engineers, Anchorage, AK</i>	
		File: Serial Port Adapters.vsd	DWG. PC-ADAPT
		Scale: None	Sheet 12 of

8 7 6 5 4 3 2 1

H

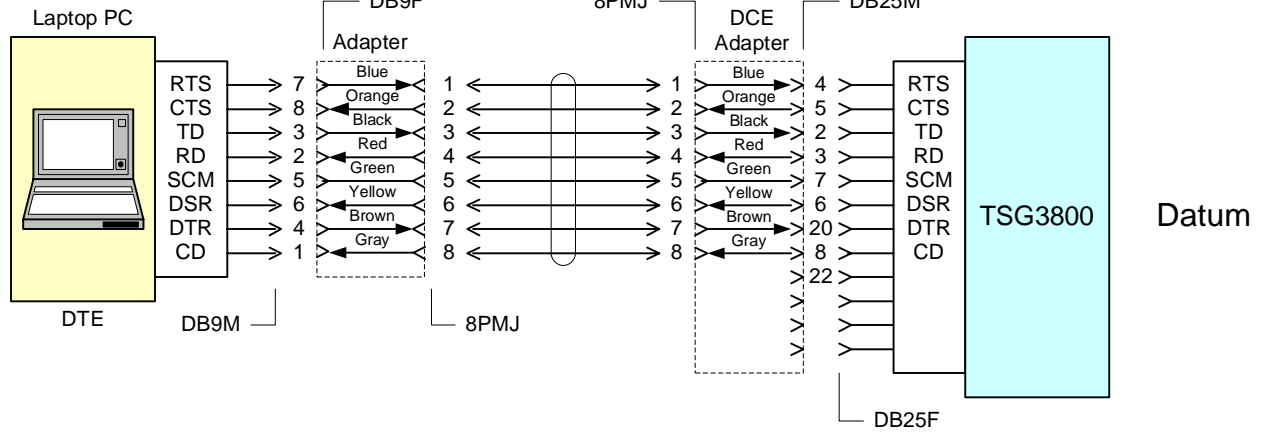

H

G

G

F

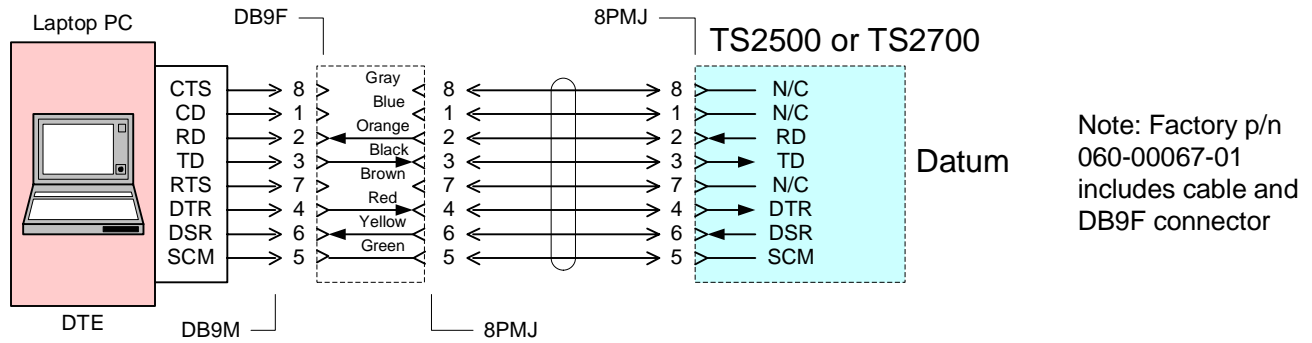

F

E

E

D

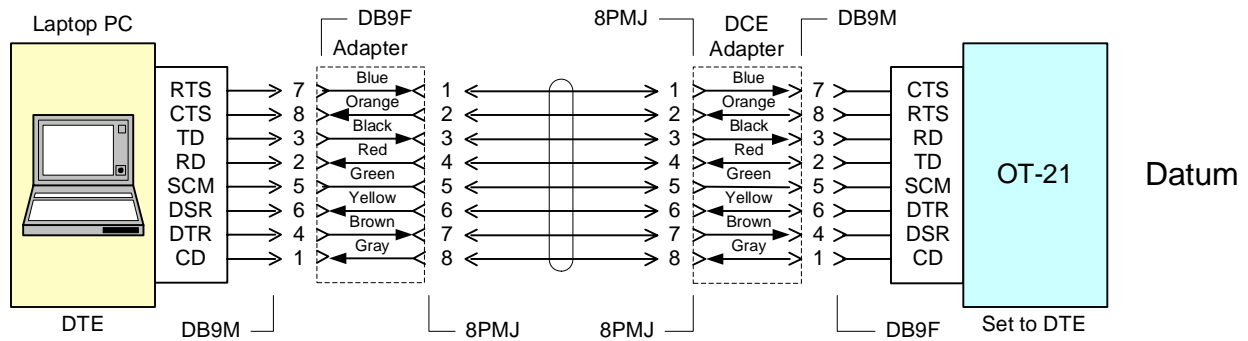

D

C

C

B

B

A

A

Revisions		© 2004 Reeve Engineers	
A	Orig. 9/30/04	PC and Equipment Serial Port Adapter Wiring	
		Reeve Engineers, Anchorage, AK	
		File: Serial Port Adapters.vsd	DWG. PC-ADAPT
		Scale: None	Sheet 13 of

8 7 6 5 4 3 2 1

8 7 6 5 4 3 2 1

H
G
F
E
D
C
B
A

H
G
F
E
D
C
B
A

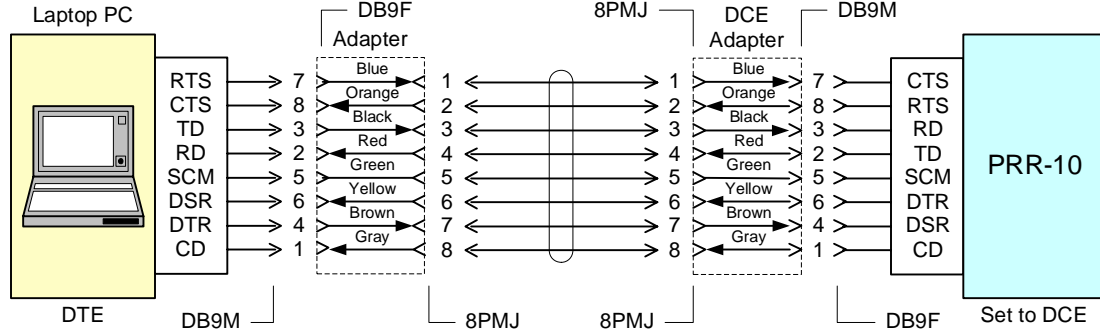

Revisions		© 2004 Reeve Engineers	
A	Orig. 11/11/04		
		PC and Equipment Serial Port Adapter Wiring	
		<i>Reeve Engineers, Anchorage, AK</i>	
		File: Serial Port Adapters.vsd	DWG. PC-ADAPT
		Scale: None	Sheet 14 of

8 7 6 5 4 3 2 1

8 7 6 5 4 3 2 1

F1080 Programming

SET #00 F=8N1 S=9600 I=10 N=TERMINAL O=BCEIMNOX	
SET #01 F=8N1 S=9600 I=10 N=A O=EIX	
SET #02 F=8N1 S=9600 I=10 N=B O=EIX	
SET #03 F=8N1 S=9600 I=240 N=MODEM O=BCEIMNOX H=M	
SET #04 F=8N1 S=9600 I=10 N=AUX O=EIX	H=
SET #05 F=8N1 S=9600 I=10 N=UMC1000 O=EIX	H=T
SET #06 F=7E1 S=9600 I=10 N=MDX O=EIX	H=MT
SET #07 F=8N1 S=9600 I=10 N=HDSL O=EIX	

FastComm F1080

Data Controller

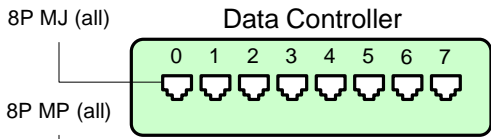

Laptop PC

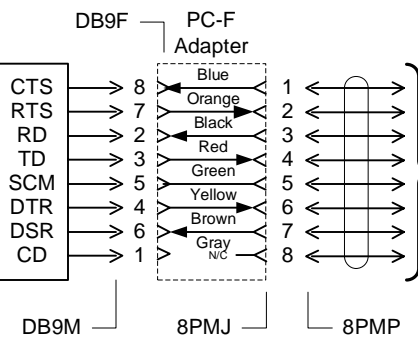
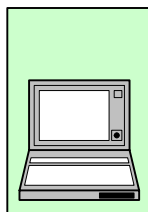

Modem

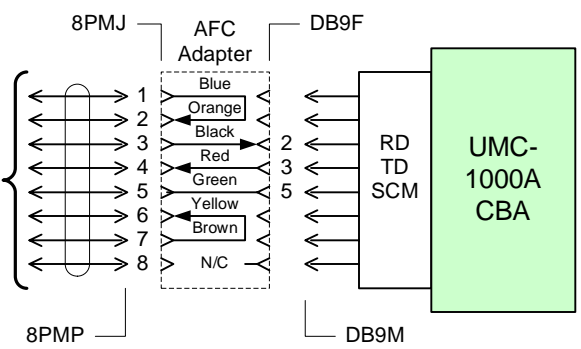
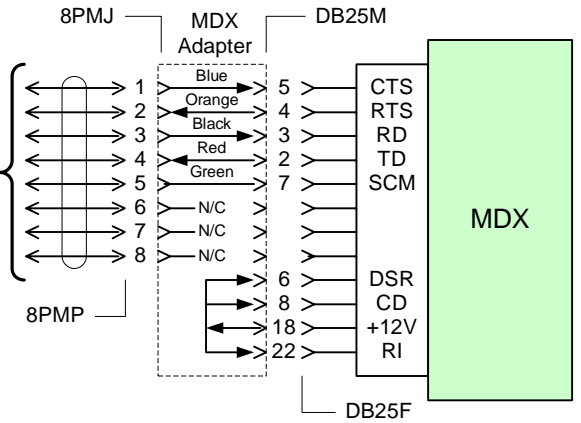
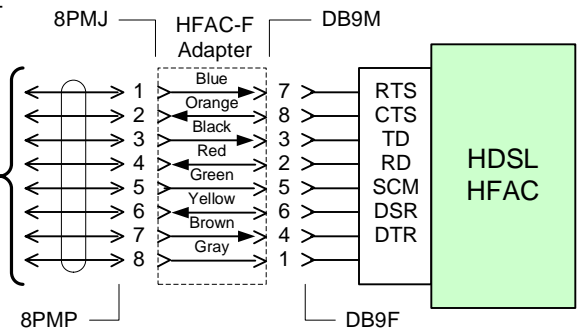
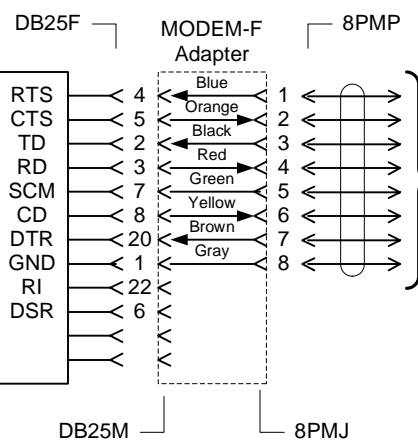
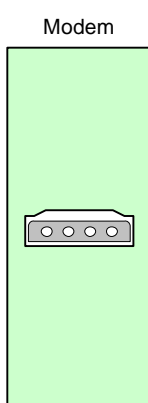

Notes:

- All cables with 8-position modular connectors wired straight-thru.
- Color codes of 8-pin modular jacks (8P MJ) may vary from those shown. Always check jack pinouts before committing wiring.
- Adapter p/n (Milestek):

DB9M	10-01042
DB9F	10-01043
DB25M	10-01046
DB25F	10-01047

Revisions		© 1999 Reeve Engineers	
A	Orig. 12/24/98		
B	Corr. 10/29/99	I/O Cabling Configurations with Fastcomm F1080A	
		<i>Reeve Engineers, Anchorage, AK</i>	
		File: Serial Port Adapters.vsd	DWG. F1080A-I/O
		Scale: None	Sheet 1 of 2

8 7 6 5 4 3 2 1

F1080 Programming

SET #00	F=8N1	S=9600	I=10	N=TERMINAL	O=BCEIMNOX	
SET #01	F=8N1	S=9600	I=10	N=A	O=EIX	
SET #02	F=8N1	S=9600	I=10	N=B	O=EIX	
SET #03	F=8N1	S=9600	I=240	N=MODEM	O=BCEIMNOX	H=M
SET #04	F=8N1	S=9600	I=10	N=AUX	O=EIX	
SET #05	F=8N1	S=9600	I=10	N=UMC1000	O=EIX	H=
SET #06	F=8N1	S=9600	I=10	N=GPS PRS	O=EIX	H=ST
SET #07	F=8N1	S=9600	I=10	N=HDSL	O=EIX	H=MT

FastComm F1080

Data Controller

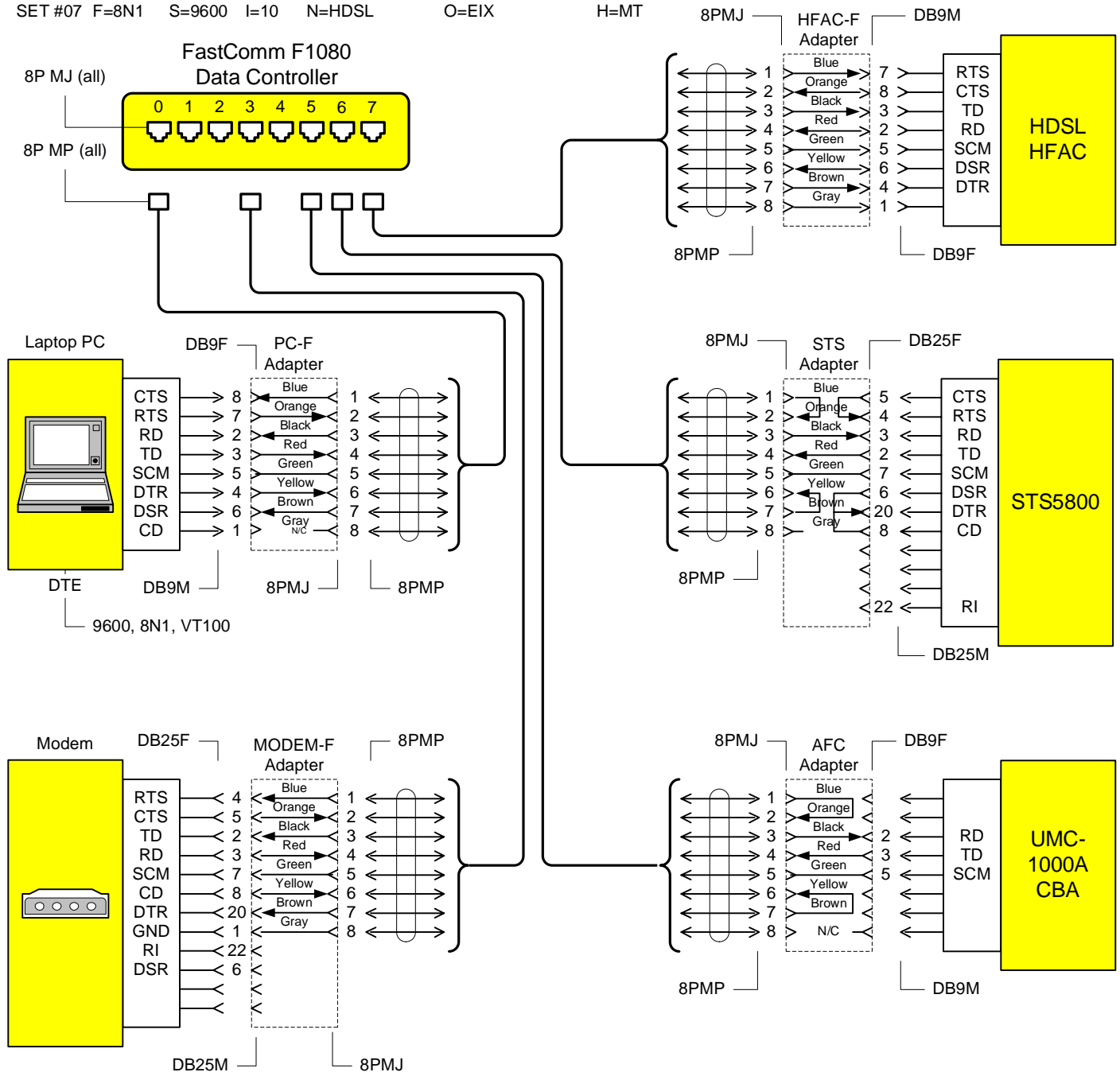
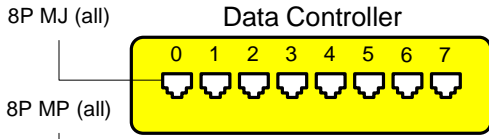

Notes:

- All cables with 8-position modular connectors wired straight-thru.
- Color codes of 8-pin modular jacks (8P MJ) may vary from those shown. Always check jack pinouts before committing wiring.
- Adapter p/n (Milestek):

DB9M	10-01042
DB9F	10-01043
DB25M	10-01046
DB25F	10-01047

Revisions

A	Orig. 7/7/99

© 1999 Reeve Engineers

I/O Cabling Configurations with Fastcomm F1080A

Reeve Engineers, Anchorage, AK

File: Serial Port Adapters.vsd

DWG. F1080A-I/O

Scale: None

Sheet 2 of 2

8

7

6

5

4

3

2

1

H

H

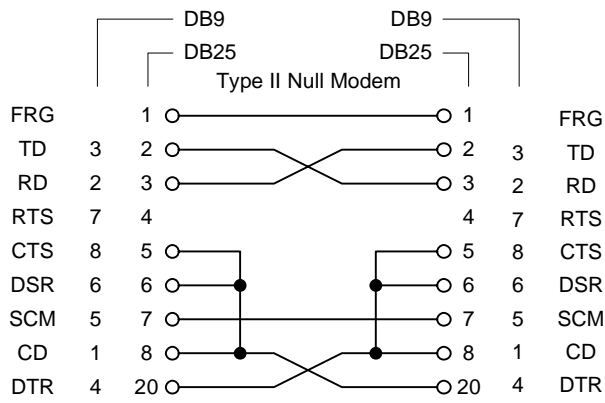
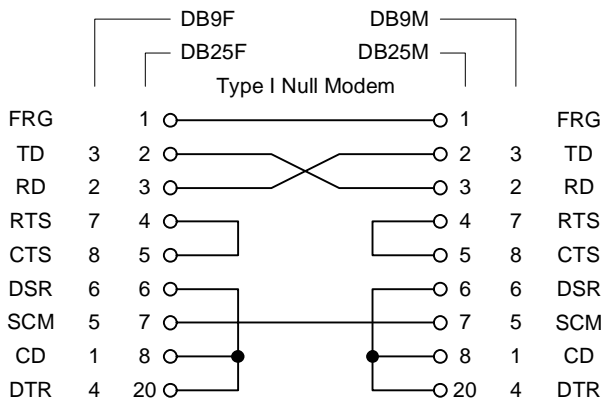

G

G

F

F

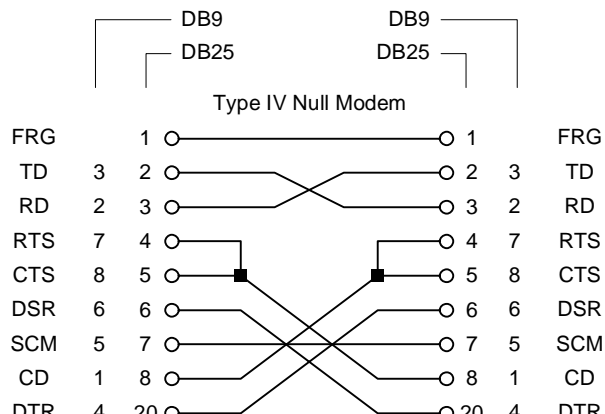
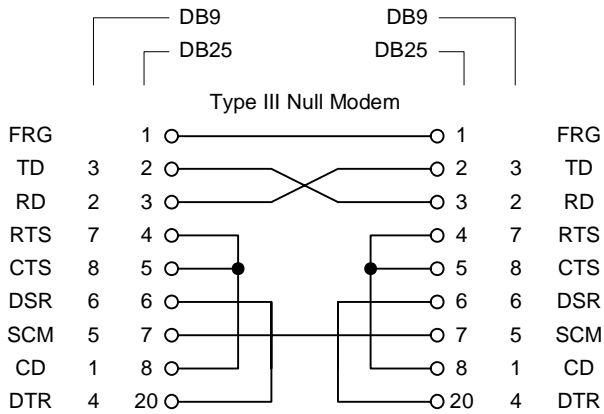

E

E

D

D

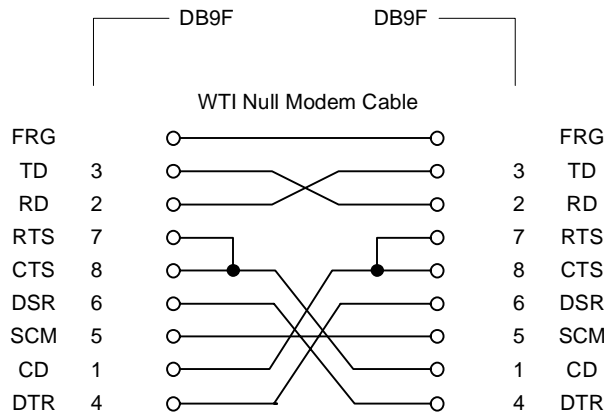

C

C

B

B

Adapter J-Box p/n (B&B Electronics):

Type	P/N
DB9M-DB9M	9PMMJB
DB9M-DB9F	9PMFJB
DB9F-DB9F	9PFFJB
DB25M-DB25M	232MMJB
DB25M-DB25F	232MFJB
DB25F-DB25F	232FFJB

A

A

Revisions		© 1999 Reeve Engineers	
A	Orig. 7/26/99	Null Modem J-Box Adapter Wiring	
		<i>Reeve Engineers, Anchorage, AK</i>	
		File: Serial Port Adapters.vsd	DWG. NULL-ADAPT
		Scale: None	Sheet 1 of 1

8

7

6

5

4

3

2

1

8 7 6 5 4 3 2 1

F1080 Programming

SET #0	F=8N1	S=9600	I=10	N=TERMINAL	O=BCEIMNOX
SET #1	F=8N1	S=9600	I=10	N=A	O=EIX
SET #2	F=8N1	S=9600	I=10	N=B	O=EIX
SET #3	F=8N1	S=9600	I=240	N=MODEM	O=BCEIMNOX
SET #4	F=8N1	S=9600	I=10	N=AUX	O=IEX

FastComm F1080 Data Controller

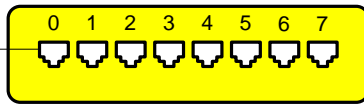

Factory Default (ATF1)

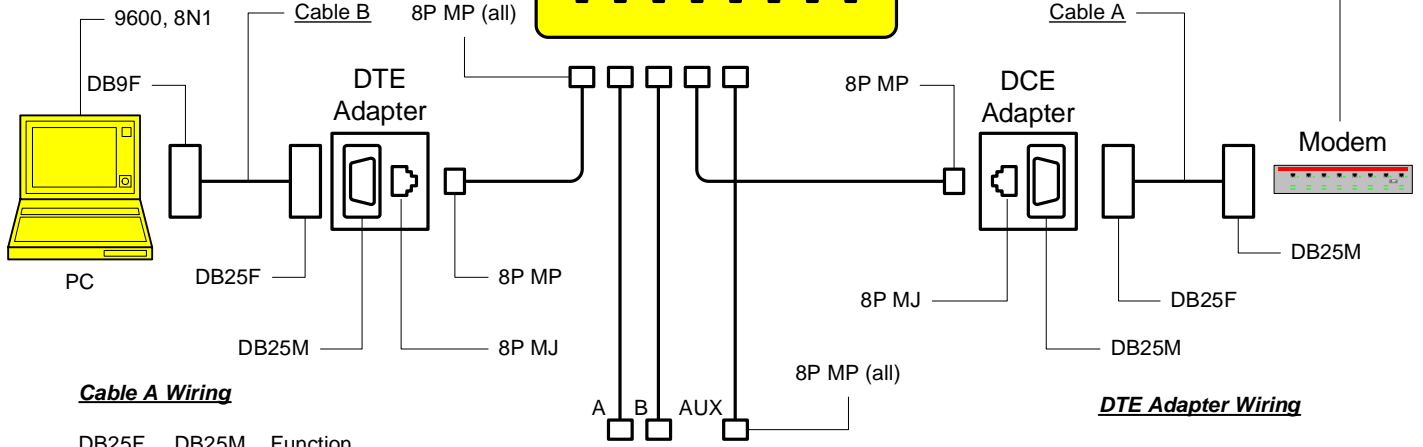

Cable A Wiring

DB25F	DB25M	Function
1	1	GND
2	2	TD
3	3	RD
4	4	RTS
5	5	CTS
6	6	DSR
7	7	COM
8	8	CD
20	20	DTR
22	22	RI

DTE Adapter Wiring

DB9	DB25	8P MJ
1 CD	8	N/C
2 RD	3	3 (black)
3 TD	2	4 (red)
4 DTR	20	6 (yellow)
5 COM	7	5 (green)
6 DSR	6	7 (brown)
7 RTS	4	2 (orange)
8 CTS	5	1 (blue)
9 RI	22	N/C

Cable B Wiring

DB9F	DB25F	Function
N/C	1	GND
3	2	TD
2	3	RD
7	4	RTS
8	5	CTS
6	6	DSR
5	7	COM
N/C	8	CD
4	20	DTR
N/C	22	RI

DCE Adapter Wiring

DB9	DB25	8P MJ
1 CD	8	N/C
2 RD	3	4 (red)
3 TD	2	3 (black)
4 DTR	20	7 (brown)
5 COM	7	5 (green)
6 DSR	6	6 (yellow)
7 RTS	4	1 (blue)
8 CTS	5	2 (orange)
9 RI	22	N/C

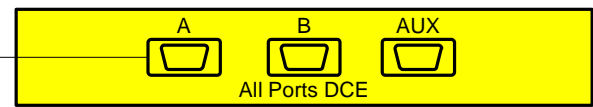
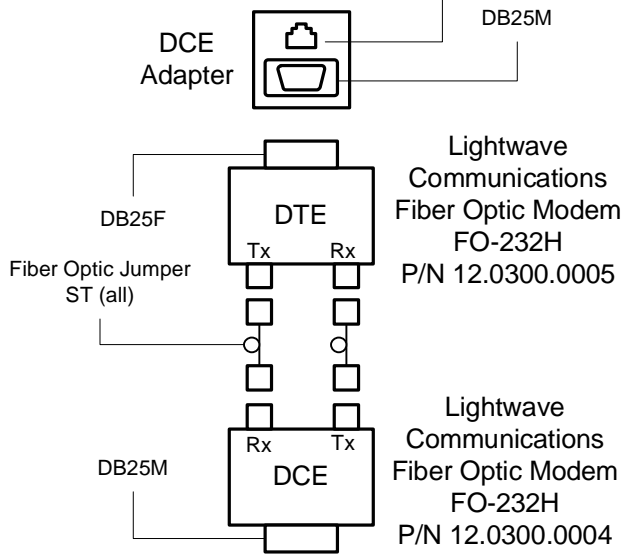

Mitel System Port Assignments: TERM, 9600, 8N1

Cable B may be used to connect a PC directly to the Mitel I/O Panel

- Notes:
1. All cables with 8-position modular connectors wired straight-thru.
 2. Color codes of 8-pin modular jacks (8P MJ) may vary from those shown. Always check jack pinouts before committing wiring.

Revisions		© 1999 Reeve Engineers	
A	Orig. 1/24/97		
		Mitel GX-5000S I/O Cabling Configurations	
		<i>Reeve Engineers, Anchorage, AK</i>	
		File: Serial Port Adapters.vsd	DWG. MITEL-I/O
		Scale: None	Sheet 1 of 1

8 7 6 5 4 3 2 1